

Index

Fundamentals	- PAG 2
Machine topologies	- PAG 3
Slotless winding	- PAG 4
Slotted winding	- PAG 5
Water cooled winding	- PAG 6
Why Axial Flux machine?	- PAG 7

Fundamentals

Radial-Flux Machine

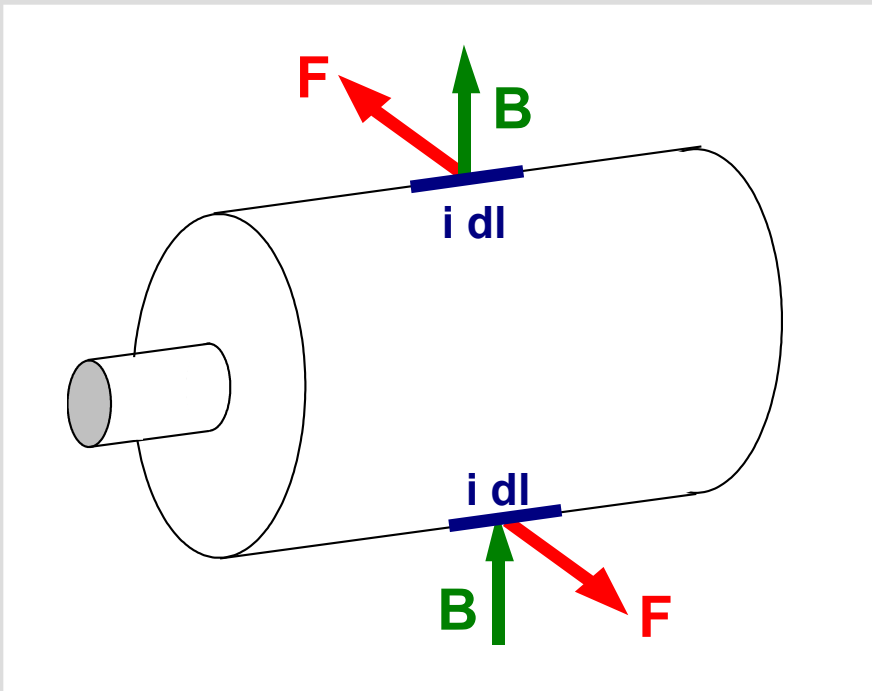

$$T = k_{rf} D^2 L$$

Axial-Flux Machine

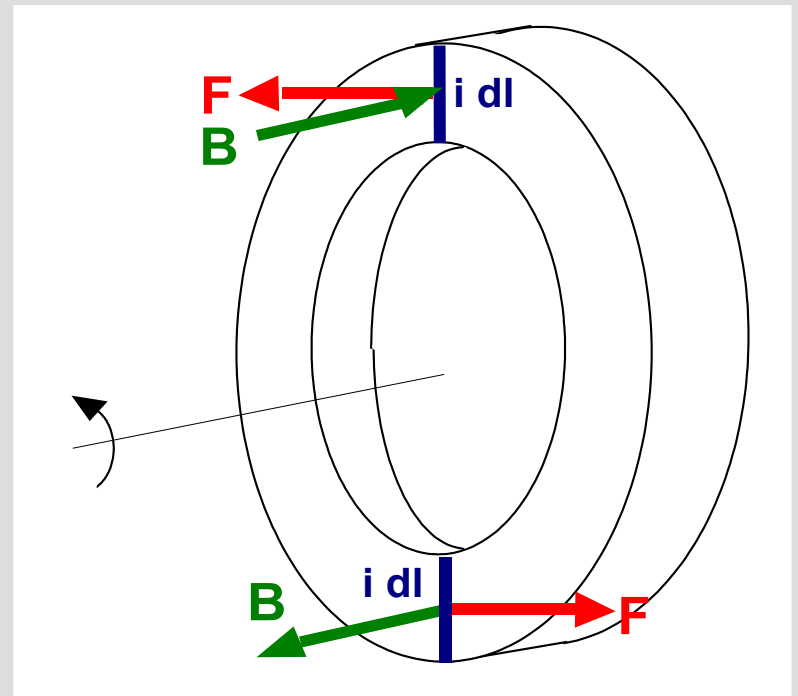

$$T = k_{af} D^3$$

Machine Topologies

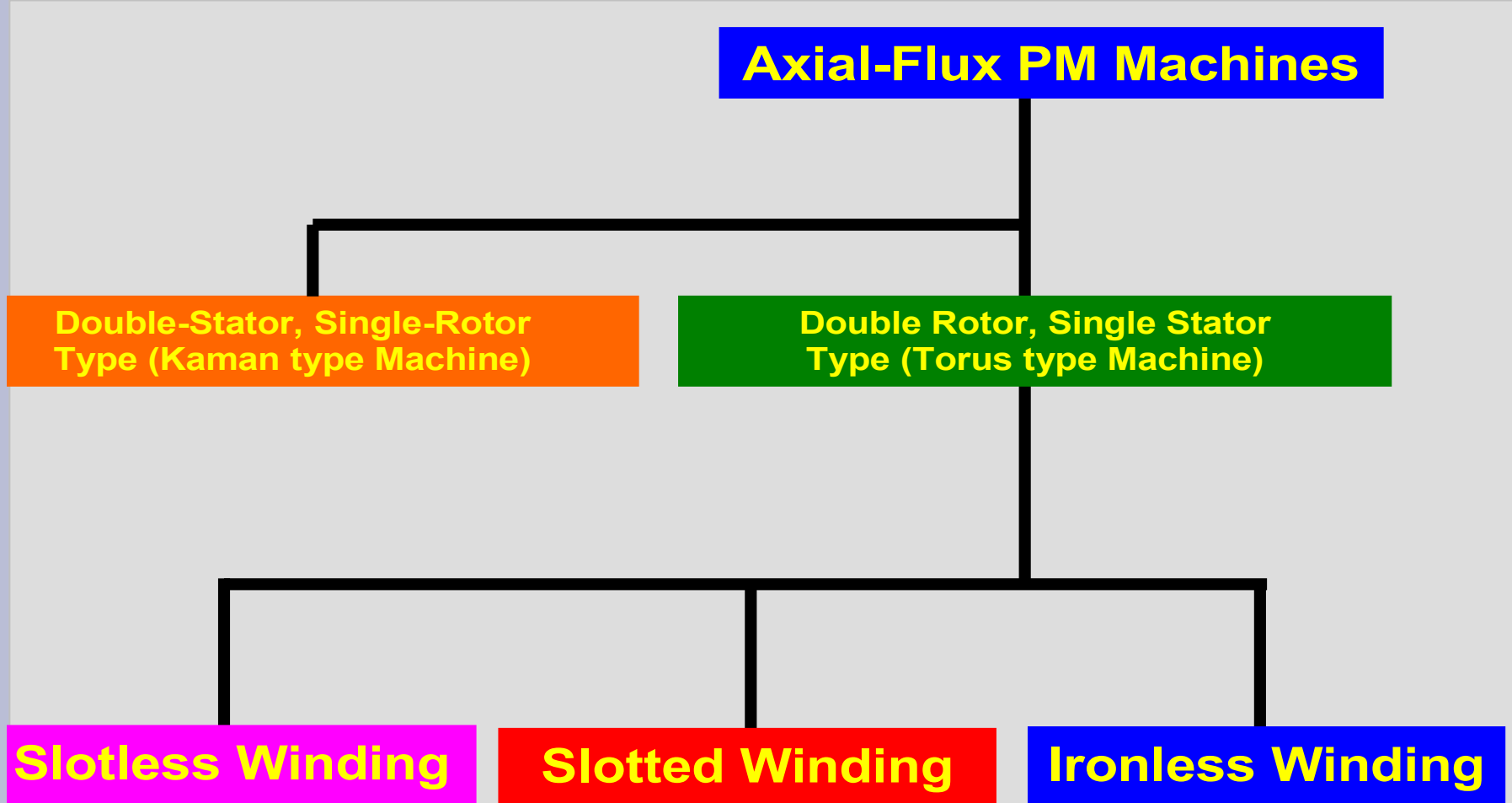

Slotless Winding Axial-Flux Machine

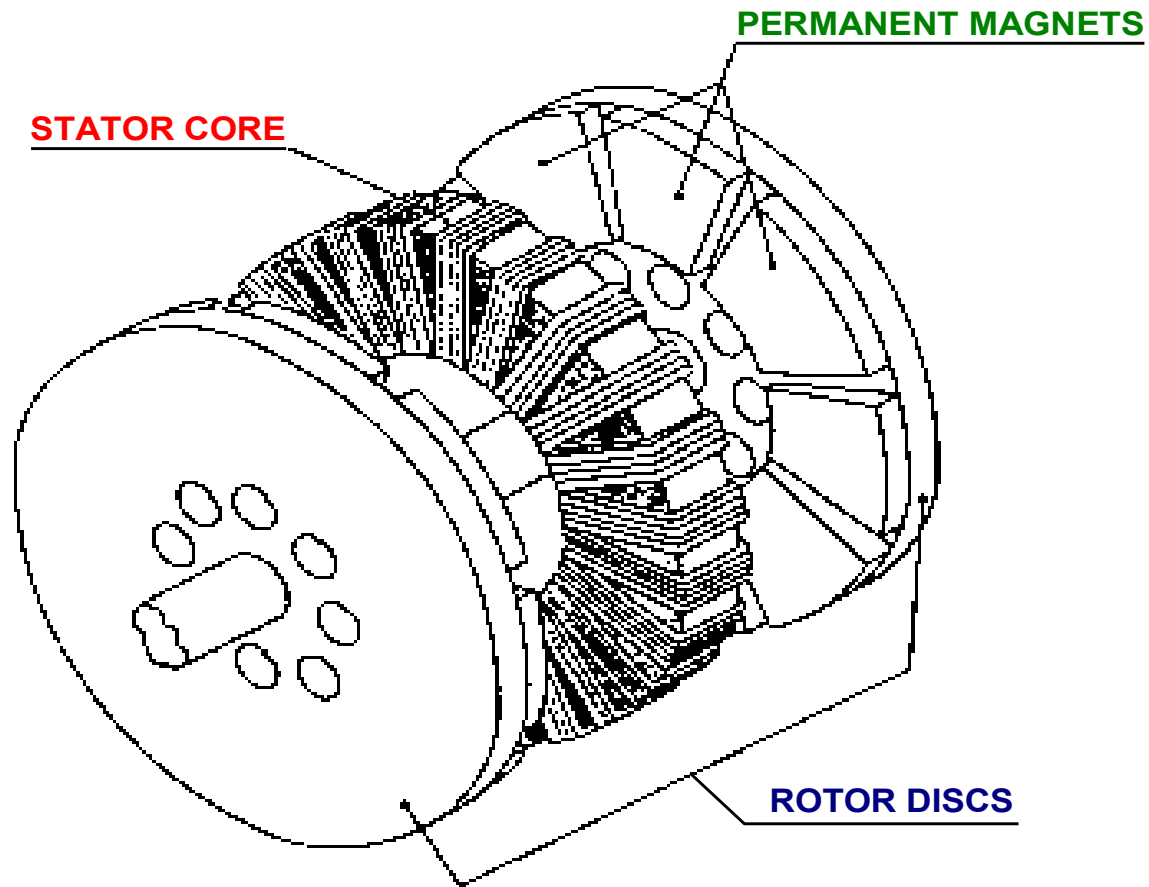

Slotted Winding Axial-Flux Machine

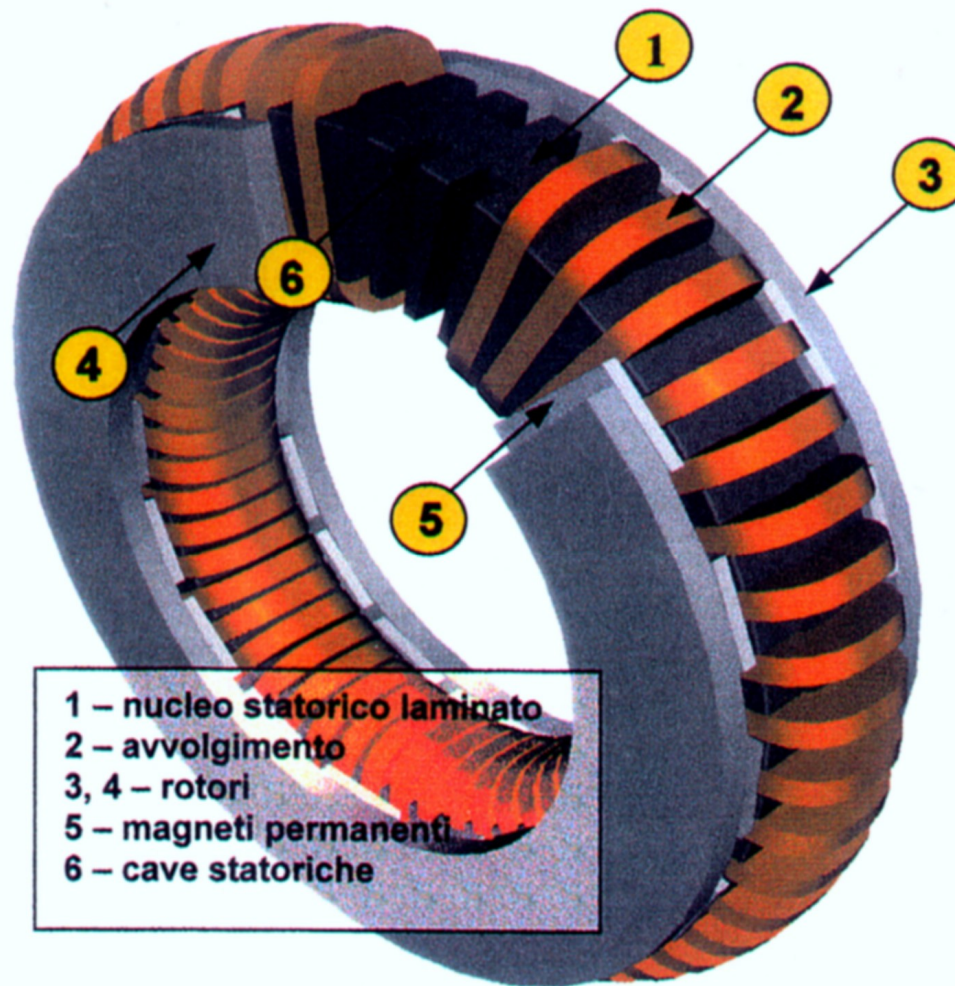

Water-Cooled Ironless Winding Axial-Flux Machine

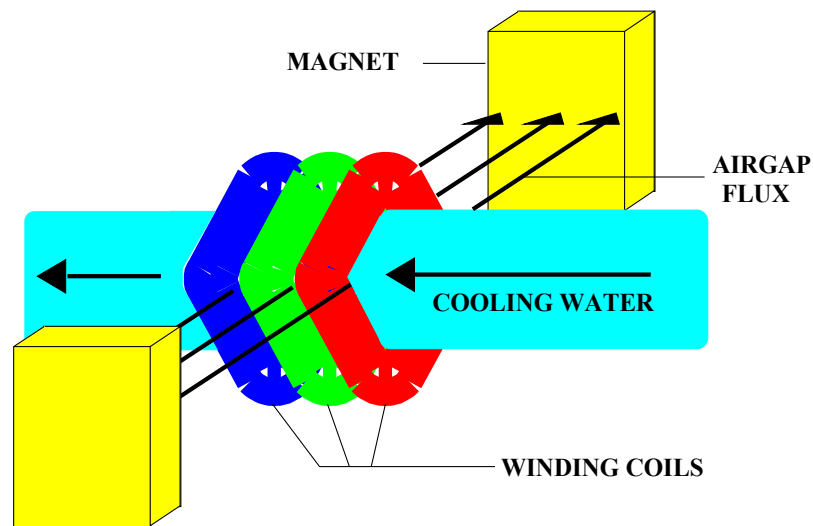
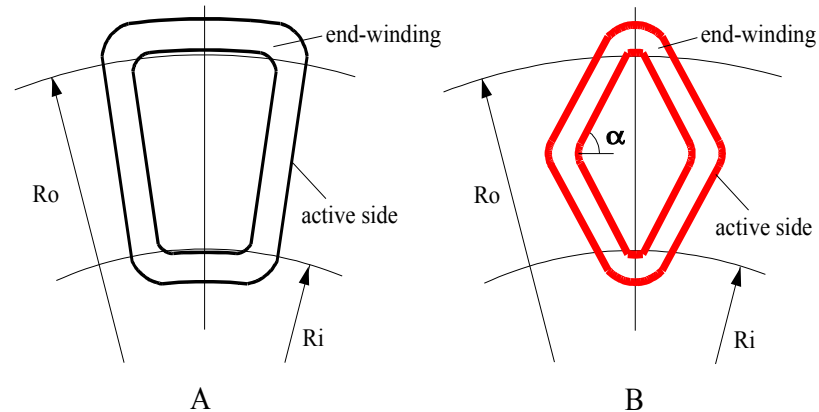
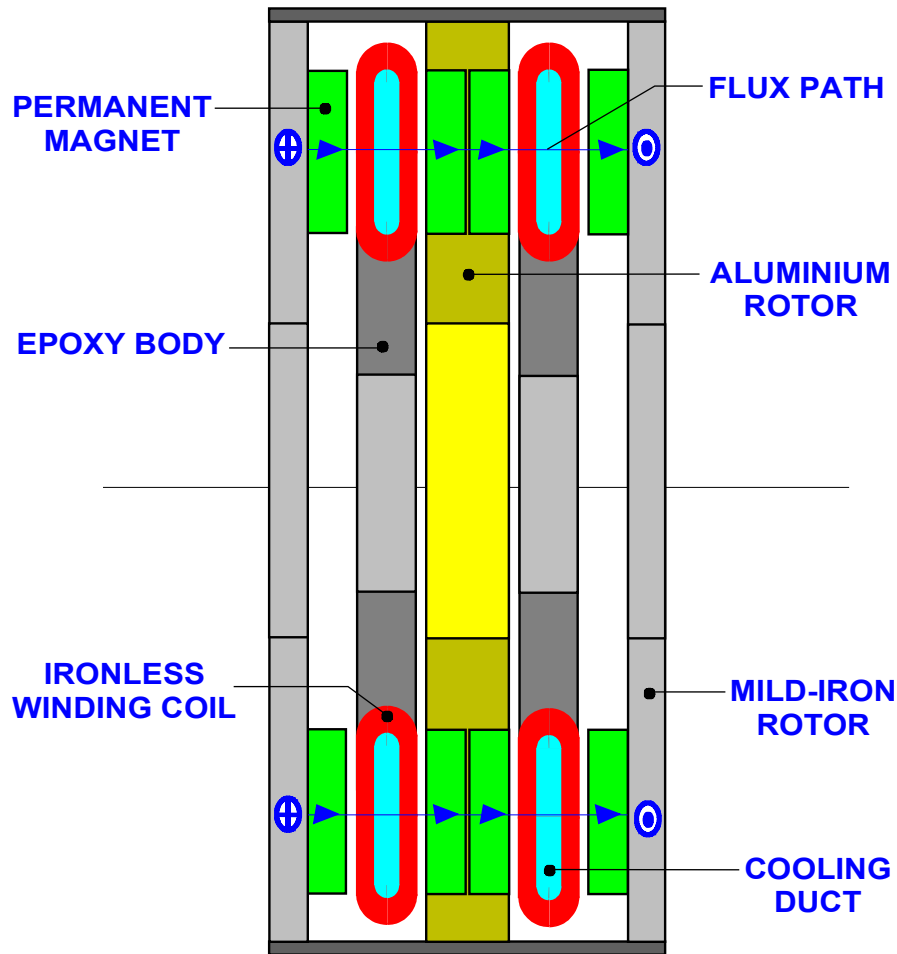

Why Axial Flux Machine?

Best-->5 Worst--> 1

	Radial Flux	Axial Flux	Transverse Flux	Vernier	DSPM
Torque Density	1	4	5	3	2
Cost	5	4	1	4	3
Overall Efficiency	4	5	2	1	3
Torque Ripple	5	5	2	3	1
Manufacturability	5	4	1	3	2
Tot.	20	22	11	14	11

- Recommendation → Axial flux Torus type geometry.